

ITD COMPACT DREDGER

CD 100

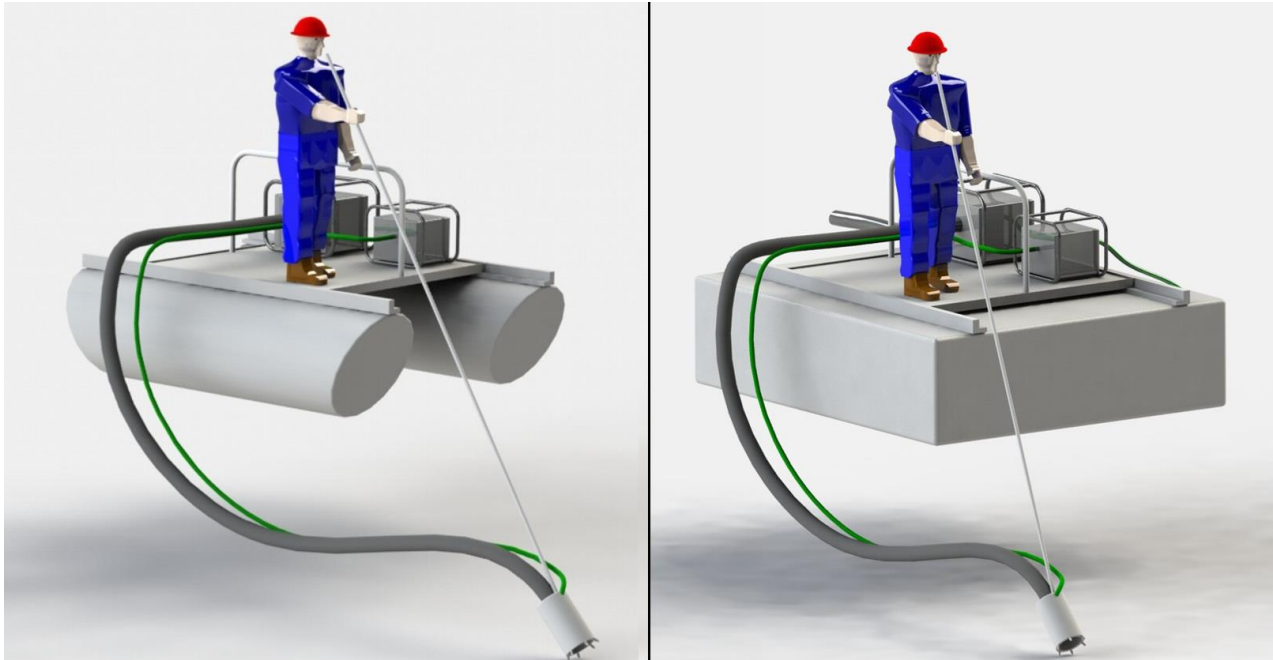

ITALDRAGHE
DREDGING AND PUMPING SOLUTIONS
since 1952



ITD COMPACT DREDGER CHARACTERISTICS:

- Removable catamaran-shaped float made with UV and chemical resistant high-density PE 100 tubing to impact and abrasion
- Hot-dip galvanized steel supporting structure with stainless steel fastening hardware
- Perforated PVC walkway flooring
- Self-priming pumps
- Available remote-control system to be operated from the shore
- Easy to operate by a single person
- Highly efficient in terms of fuel consumption
- Spare parts available from stock
- Lifetime technical support from the company

VERSATILITY:

Italdraghe differentiates from other players in the market for its flexibility given by innovative solutions designed in order to satisfy specific customer needs and to adapt to every circumstance and environment

QUALITY:

Italdraghe masters the production of high-quality products thanks to a deep know-how and expertise of the dredging industry developed over a more than 70 years' experience in the sector

EFFICIENCY:

Thanks to its exceptional pumping rate, low maintenance costs and low cost per cubic meter, Italdraghe can offer its clients highly efficient dredging products and dredging solutions

ITALDRAGHE S.p.A.

Via Malpasso 1389
47842 San Giovanni
in Marignano (RN), Italy

Tel. +39 0541 955181 - Fax +39 0541 956512
info@italdraghe.it - www.italdraghe.it
VAT/P.IVA & C.F. ITO1321800409





ITALDRAGHE

DREDGING AND PUMPING SOLUTIONS

since 1952

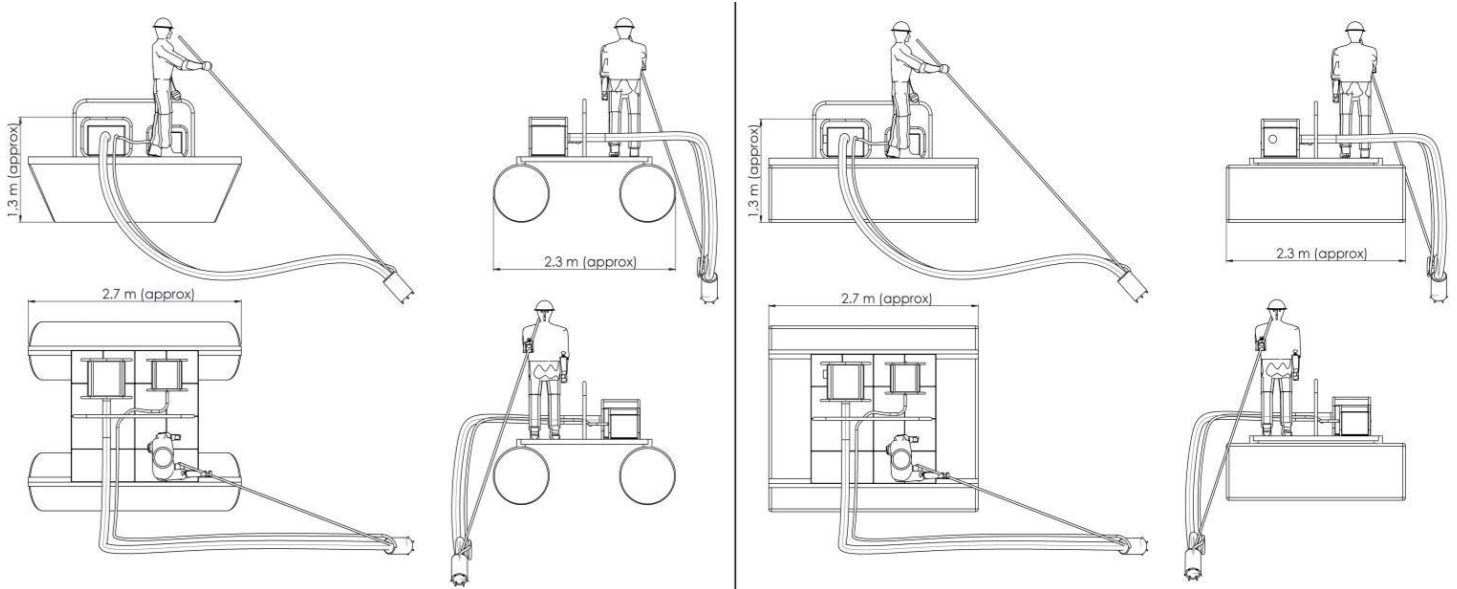

Technical data	Unit	BDR2+RH400
Length	[m]	2.70
Width	[m]	2.30
Height	[m]	1.30
Weight	[Kg]	500
Installed pumps	<ul style="list-style-type: none">• 1 dredging pump for dredging the material• 1 agitator pump for water jet system	
Max flow capacity	[L/min]	2,085

Values represented in the table might be subject to customization depending on the specific need

ITALDRAGHE S.p.A.

Via Malpasso 1389
47842 San Giovanni
in Marignano (RN), Italy

Tel. +39 0541 955181 - Fax +39 0541 956512
info@italdraghe.it - www.italdraghe.it
VAT/P.IVA & C.F. ITO1321800409

