

Cutter Suction Dredger

SGT 300

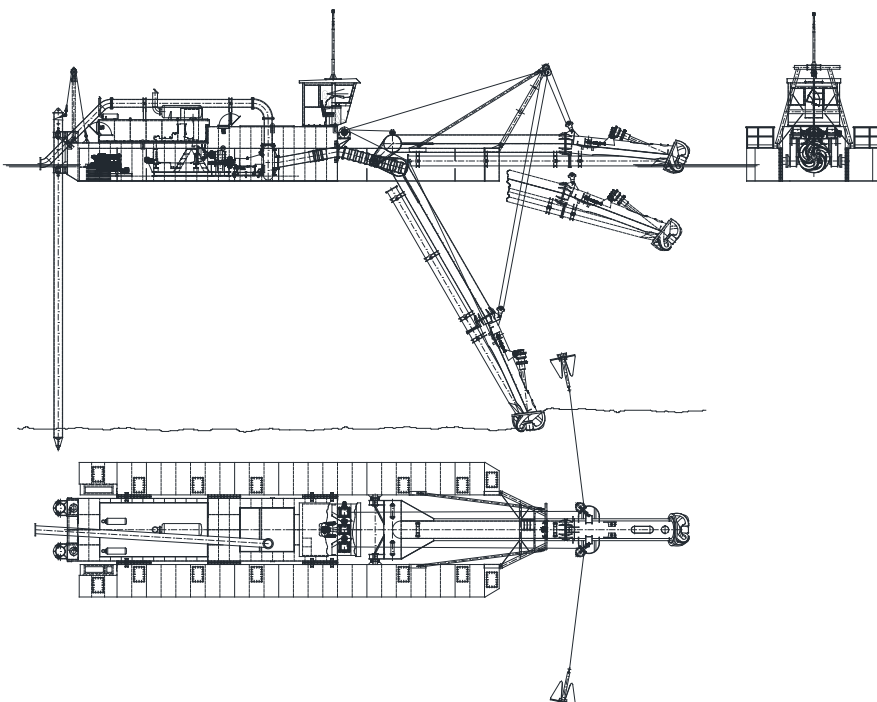

Italdraghe is specialized in manufacturing cutter suction dredgers, dredging systems with deep water submersible pumps, floating and onshore booster stations.



VERSATILITY

Italdraghe differentiates from other players in the market for its flexibility given by custom made dredgers designed in order to satisfy specific customer needs.

QUALITY

Italdraghe masters the production of high-quality dredgers thanks to a deep know-how and expertise of the dredging industry developed over a more than 60 years' experience in the sector.

EFFICIENCY

Thanks to its exceptional pumping rate, low maintenance costs and low cost per cubic meter, Italdraghe can offer its clients highly efficient dredgers.

MAIN DIMENSIONS

Overall length, ladder raised	20,70 m
Length over pontoons	13,20 m
Overall width	4,56 m
Main pontoon	8,50x2,45x2,30 m
Side pontoons	12,60x1,00x1,50 m
Maximum standard dredging depth	8 m
Average draught, approx	0,90 m
Suction diameter	300 mm
Delivery diameter	300 mm

DIESEL ENGINE

Caterpillar C18 TA ACERT (or equivalent)	
Continuous power at rpm	429 KW @ 1800 rpm

DREDGING PUMP

Italdraghe RPV - SGT 250NB

CUTTER

Power	50 KW
Max speed	0-35 rpm
Diameter	1000 mm

LADDER AND SWING WINCHES

First layer pull	3,5 Ton
Wire diameter	14 mm
Wire length	80 m
Anchor weight	250 Kg

SPUDS

Hydraulically operated jacks	
Diameter	273 mm
Length	12 m
Weight	1,50 Ton/each

ELECTRICAL INSTALLATION

24 V DC

CLASSIFICATION

Bureau Veritas Class I, * Hull • MACH Dredger - no propulsion
Coastal area

MAIN CHARACTERISTICS

- Available custom made in order to satisfy specific customer requests
- Easy to operate by a single person from the control cabin
- Dismountable and transportable by road, rail or sea
- On site operator at delivery time for mounting and testing the dredger
- Moved by diesel or electric engine
- Environmental friendly dredger
- Low maintenance costs
- Exceptional rate of pumping power
- Highly efficient in terms of fuel consumption
- Large engine room that enables the operator to perform maintenance in security and in comfort
- Spare parts available from stock
- Lifetime technical support from the company

ADDITIONAL FEATURES

- Spud carriage installation
- Anchor booms (enlarged side pontoons)
- Auger head
- Swivel bend
- Discharge and vacuum-relief valve
- Positioning system
- Increased dredging depth
- Increased discharge pipeline length/diameter
- Control cabin placed on dampers to improve comfort and reduce noise
- Air conditioning
- Wide range of services and optional equipment available - pipelines, boosters and work boats
- In loco operators' training

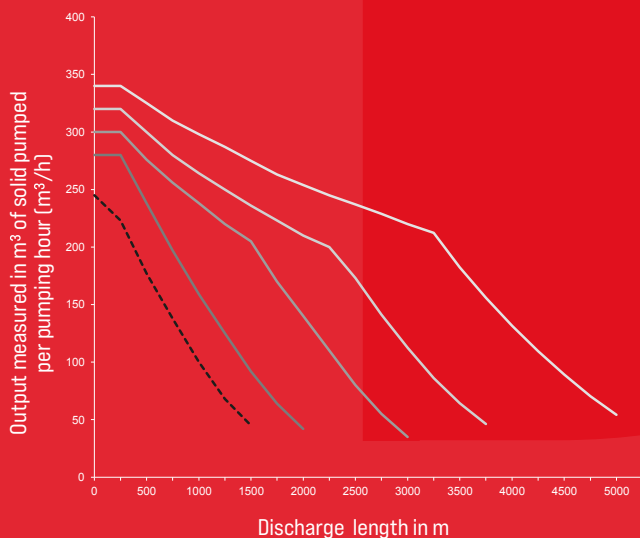

CURVE	MATERIAL TYPE	GRAIN SIZE	SPECIFIC DENSITY
— (top)	Fine sand	0,10 mm	1,90 t/m ³
—	Medium sand	0,24 mm	1,95 t/m ³
—	Coarse sand	0,44 mm	2,00 t/m ³
—	Coarse sand + gravel	1,30 mm	2,10 t/m ³
- - - (bottom)	Gravel	7,00 mm	2,20 t/m ³

The curves represented in the graph indicate the maximum output. Please note that to calculate the effective output, they have to be adjusted according to the type of material to be pumped and the specific working conditions.

Via Malpasso, 1389 - San Giovanni in Marignano, 47842 (RN) - Italy
tel. +39 0541 955181 - fax +39 0541 956512 - mob. +39 335 7019671

info@italdraghe.it
www.italdraghe.it

