

Bow Thruster

GTF

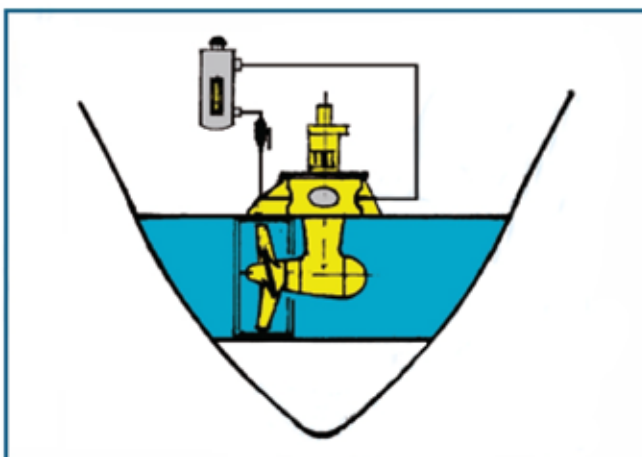

Bow thrusters are transversal propulsion devices that can be installed either on the bow or on the stern of a vessel. They allow the vessel to move sideways, in tight spaces and at low speeds in situation of poor visibility or danger of collision. Italdraghe has specialized in the manufacturing of a wide range of reliable heavy-duty thrusters designed to guarantee continuous operation in all working conditions. Their uniqueness is given by the fact that they are realized with high quality and durable materials and that they are suitable for a wide range of vessels as they are available in different sizes and models.



QUALITY

Italdraghe masters the production of high-quality bow thrusters thanks to a deep know how and expertise of the marine construction industry developed over a more than 60 years' experience in the sector

VERSATILITY

Italdraghe differentiates from other players in the market for the flexibility and application versatility that characterize its products. Indeed, Italdraghe bow thrusters are available in multiple models (diesel, hydraulic, electric driven in different powers) in order to comply with specific customer needs

EASY MAINTENANCE

Italdraghe has developed a bow thruster model that allow easy routine maintenance operations without having to take the vessel off the water

Hydraulic type GTF-I

Model	Unit	GTF-I 040	GTF-I 075	GTF-I 100	GTF-I 200	GTF-I 300	GTF-I 400	GTF-I 500
Max power*	Kw	20-30	40-90	90-135	135-200	250-315	330-450	450-560
Input speed	rpm	2500-3000	3000-3600	3000-3600	2800-3600	2200-2750	2200-2750	2000-2240
Propeller diameter**	mm	240-290	320-550	620	700	900	1000	1200

*Rating subject to classification and application

**Diameters may vary depending on particular applications

Electrical type GTF-E

Model	Unit	GTF-E 040	GTF-E 075	GTF-E 100	GTF-E 200	GTF-E 300	GTF-E 400	GTF-E 500
Max power*	Kw	22-37	45-90	90-132	160-200	250-315	355-450	450-500
Input speed	rpm	3000	3000	3000	3000	1500	1500	1500
Propeller diameter**	mm	240-290	320-550	620	700	900	1000	1200

*Rating subject to classification and application

**Diameters may vary depending on particular applications

MAIN CHARACTERISTICS - BENEFITS

- Powered by:
 - Hydraulic motor – can be connected either horizontally or vertically and thus incorporated optimally into the naval architectural design
 - Electric motor – can be connected either horizontally or vertically and thus incorporated optimally into the naval architectural design
- High efficiency and reliability
- Able to reach the maximum thrust in a very short time
- Quick thrust inversion
- Tailored configuration – in order to obtain the maximum thrust Italdraghe bow thruster design can be adapted to vessels of different architectures
- Compatible with any type of watercraft - available in a wide range of models according to different power and configuration requirements
- Fast installation
- Provided with lubrication system, watertight seals and compensation tank
- Easy maintenance – routine maintenance can be carried out from inside the vessel
- Spare parts available from stock
- Manufactured in accordance with RINA (Italian Naval Registry) specifications
- Management quality systems are accredited to ISO 9001:2015

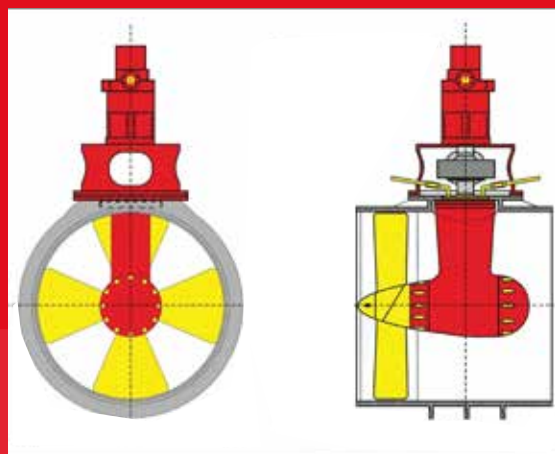

Via Malpasso, 1389 - San Giovanni in Marignano, 47842 (RN) - Italy
tel. +39 0541 955181 - fax +39 0541 956512 - mob. +39 335 7019671

info@italdraghe.it
www.italdraghe.it

